

FSTE...

**FLANGIA
A SALDARE
DI TESTA
HEAD
WELDING
FLANGE**

SIGLA CODE	S.A.E.	A	B	C	E	H	I	L	M	Viti Bolts	OR O-RING	Pressione max Max. pressure bar
Serie 3000 psi												
FSTE038E3	3/8"	17,5	13	36	16	57	38,1	46	17,48	M8x30	4075	348
FSTE012E3	1/2"	21,5	13	36	16	57	38,1	46	17,48	M8x30	4075	348
FSTE034E3	3/4"	28	19	36	18	65	47,63	50	22,23	M10x35	4100	348
FSTE001E3	1"	34	25	38	18	70	52,37	55	26,19	M10x35	4131	348
FSTE114E3	1" 1/4	42,8	32	41	21	81	58,72	70	30,18	M10x40	4150	278
FSTE112E3	1" 1/2	48,6	38	44	25	95	69,85	78	35,71	M12x45	4187	210
FSTE002E3	2"	61	51	45	25	102	77,77	95	42,88	M12x45	4225	210
Serie 6000 psi												
FSTE038E6	3/8"	17,5	13	36	16	57	40,49	46	18,24	M8x30	4075	420
FSTE012E6	1/2"	21,5	13	36	16	57	40,49	46	18,24	M8x30	4075	420
FSTE034E6	3/4"	28	19	35	21	71	50,8	60	23,8	M10x35	4100	420
FSTE001E6	1"	34	25	41	21	81	57,15	70	27,76	M12x45	4131	420
FSTE114E6	1" 1/4	42,8	32	44	25	95	66,68	78	31,75	M14x50	4150	420
FSTE112E6	1" 1/2	48,6	38	55	30	112	79,38	95	36,5	M16x55	4187	420
FSTE002E6	2"	61	51	65	37	134	96,82	114	44,45	M20x70	4225	420

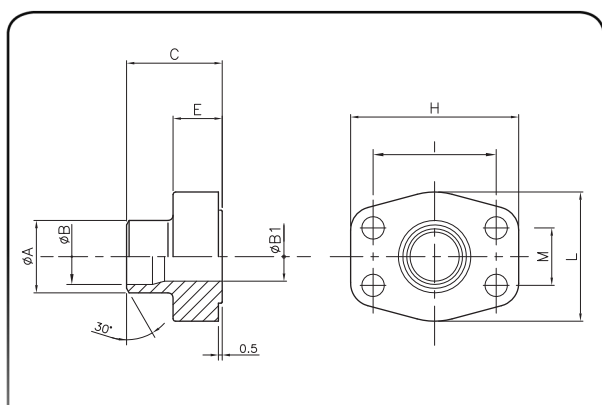

FSTETM...

**FLANGIA
A SALDARE
DI TESTA
TUBO METRICO
HEAD
WELDING FLANGE
FOR METRIC PIPE**

SIGLA CODE	S.A.E.	A	B	B1	C	E	H	I	L	M	Viti Bolts	Pressione max Max. pressure bar
Serie 3000 psi												
FSTETM20E3	1/2"	20	14	13	36	16	57	38,1	46	17,48	M8x30	348
FSTETM22E3	1/2"	22	16	13	36	16	57	38,1	46	17,48	M8x30	348
FSTETM28E3	3/4"	28	21,5	19	36	18	65	47,63	50	22,23	M10x35	348
FSTETM35E3	1"	35	27	25	38	18	71	52,37	60	26,19	M10x35	348
FSTETM43E3	1" 1/4	43	36	31	41	21	81	58,72	70	30,18	M10x40	278
FSTETM49E3	1" 1/2	49	42	38	44,5	25	95	69,85	78	35,71	M12x45	210
FSTETM6153E3	2"	61	53	49	45	25	102	77,77	95	42,88	M12x45	210
Serie 6000 psi												
FSTETM6140E6	1" 1/2	61	40	38	55	30	112	79,38	95	36,5	M16x50	420